

Name: _____

Sun–Earth Motion Activity Worksheet

Data Table

Length of first shadow (cm)	
Length of last shadow (cm)	
Distance shadow moved in 30 minutes (cm)	

Post-Lab Questions

1. Using the compass directions drawn on the sheet of paper, what direction did the shadow move across the paper?
2. Compare the length of the first shadow distance measured versus the last shadow measured. Explain the difference (if any).
3. How far did the shadow move in 30 minutes?
4. What direction did the Sun move during the 30 minutes data was recorded?
5. Did the Sun move in the same direction the Earth rotates?
6. If the length of the wood dowel and pin used in this activity was lengthened, would this affect the distance the shadow moved across the paper in 30 minutes?

Construction of the Sundial

1. Obtain the wood dowel rod, wood board, pin and paper punched with one hole.
2. Place the paper on top of the wood board so the hole lines up with the hole in the wood board (see Figure 1).
3. Place the wood dowel rod through the hole of the paper and into the hole in the wood board (see Figure 2).
4. Stick the pin into the center of the top end of the dowel rod (see Figure 2).
5. Tape the paper to the wood board so it is secure.

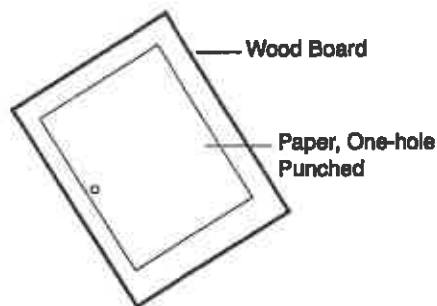

Figure 1.

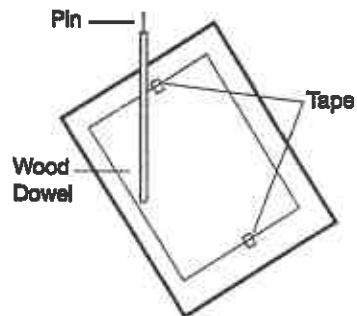

Figure 2.

Procedure

1. Take the sundial outside on a sunny day. Align the sundial so that the shadow of the wood dowel rod and pin extends across and is perpendicular to the paper. (see Figure 3).
2. Obtain a magnetic compass and place it next to the shadow of the wood dowel rod and pin. Using a pencil, record the directions North, South, East and West on one of the corners of the paper (see Figure 4).
3. Notice the shadow created by the head of the pin. Using a pencil, place a dot at this point. Record the current time (to the minute) next to the dot. Do not move the sundial after the first dot is made!
4. Wait five minutes and, using a pencil, mark a dot at the new location of the pin's shadow. Record the new time (to the minute) next to the dot.
5. Wait five more minutes and repeat step 5.
6. Continue marking new dots for a total of 30 minutes. A total of seven dots should be marked and labeled with the appropriate time.
7. Remove the wood dowel from the wood board.
8. Remove the piece of paper from the wood board. Using a ruler and a pencil, draw a line connecting all seven of the dots. Draw an arrow showing the direction of movement of the shadow (see Figure 5).
9. Using a ruler, measure the length of the shadow from the center of the hole of the paper to the marked dot. Record this value (in cm) in the Data Table.
10. Measure and record the distance from the center of the hole in the paper to the last marked dot. Record this value (to the nearest 0.1 cm) in the Data Table.
11. Measure the length of the line connecting all of the dots. Record this value (to the nearest 0.1 cm) in the Data Table. This line represents the distance the shadow moved in 30 minutes.
12. Answer the *Post-Lab Questions*.

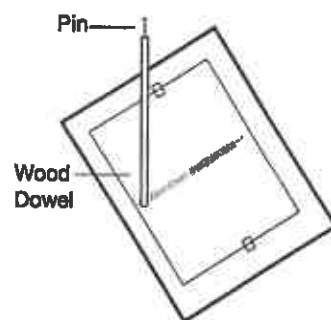

Figure 3.

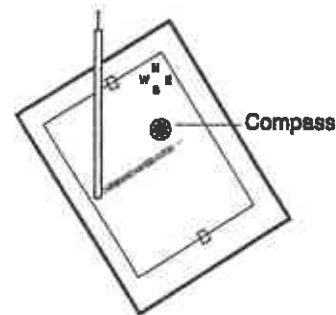

Figure 4.

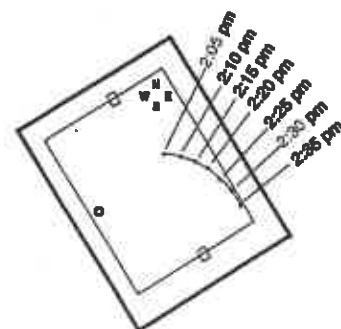

Figure 5.